

# 船用导缆滚轮 Marine Roller for Fairlead



滚轮直径 Roller Dia. (mm)	缆索最大直径 Max. Wire Dia.(mm)			外形尺寸 Dimension(mm)	
	钢索Wire Rope		麻索 Hemp Rope		合成纤维索 Compound Fibrin Rope
	6 × 24	6 × 37	45 ~ 85		32 ~ 80
150 ~ 450	17 ~ 44.5	15 ~ 43	45 ~ 85	32 ~ 80	Φ240 × 154 ~ Φ630 × 316

Code: 112118

☼ 供应商: 3130  
☼ Supplier: 3130

## 导缆器 Free Sheave

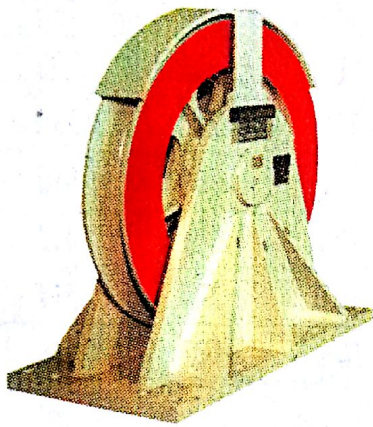

外形尺寸 Dimension	滑轮尺寸 Sheave Size (mm)	底座宽 Base Width (mm)	底座长 Base Length (mm)	钢索直径Wire Dia. (mm)	
				Min.	Max.
500-25	457	305	508	22.2	25.4
500-31	610	381	660	19.1	31.8
500-38	660	406	711	25.4	38.1
500-44	864	508	914	38.1	44.5
500-51	1016	584	1067	31.8	51
500-64-76	1067	700	1300	64	76.2

↓ Certificate: ABS, LR, RINA.

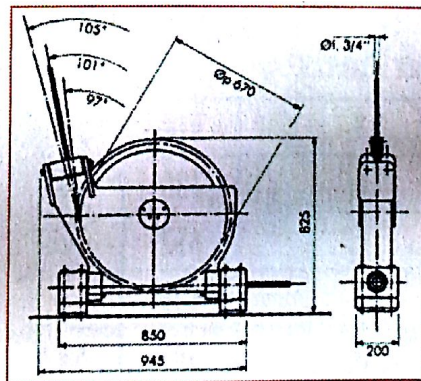
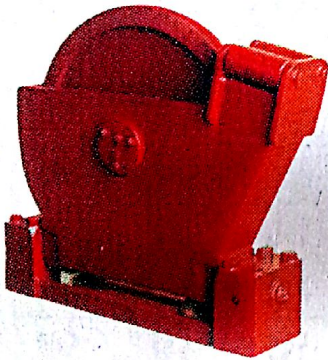

Code: 112119

☼ 供应商: 3130  
☼ Supplier: 3130

## 导缆器 Turn Down Sheaves

带有凹槽的导缆轮由高质量的钢材加工而成，球面经过耐磨处理，适用绳径为1 3/4" 和 3/4"。螺枪为镍铬特种钢制成，转轴有降低磨擦的青铜轴衬，可选规格：直径52"(起升张力轮)直径28"(导向张动轮)

Sheave of high quality steel machine grooved for 1 3/4" and 3/4" wire rope. Ball bearings proof screened. Pins of special steel Ni-Cr. Rotation on antifriction bronze bushings with lubricant provision. Available sizes: 52" dia (Riser tensioner), 28" dia (Guideline tensioner)

↓ Notes: Certificate ABS, LR, RINA.

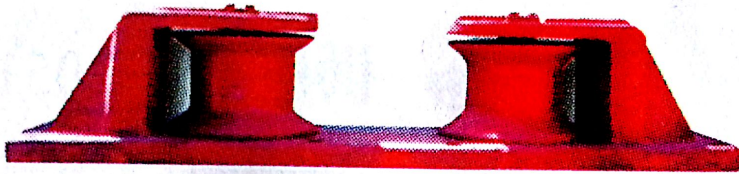

☼ 供应商: 2112  
 ☼ Supplier: 2112

铸造滚轮导缆钳 CB39-66 Cast Roller Chock

Unit: mm

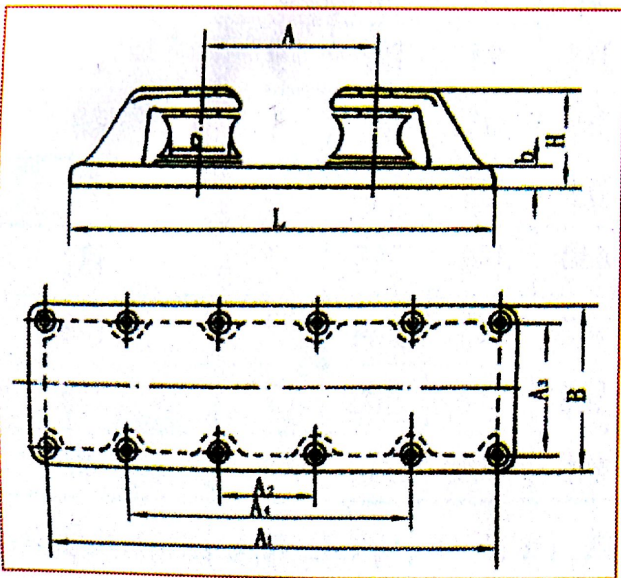

滚轮直径 Roller Dia. D		75 ~ 250
L		640 ~ 1700
B		175 ~ 420
H	Cast Iron	168 ~ 340
	Cast Steel	158 ~ 325
A		240 ~ 640
A3		115 ~ 310
重量 Weight (Kg ≈)	Cast Iron	50 ~ 721
	Cast Steel	44 ~ 687

⚓ Notes: Certificate ABS, BV, CCS, DNV, GL, KR, LR, NK, RINA.

# 船用导缆滚轮 GB/T10105-1988 Marine Fairlead Roller

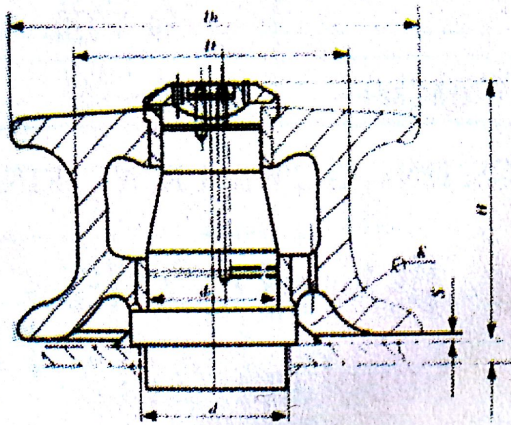

滚轮直径 Roller Dia. D		150 ~ 450	
适用缆索 最大直径 Max. Rope Dia.(mm)	钢索 Wire Rope (GB1102-74)	6 × 24	17 ~ 44.5
		6 × 37	15 ~ 43
	合成纤维索 Synthetic Fibre Rope		32 ~ 80
	麻索 Hemp Rope		45 ~ 85
外形尺寸 Dimensions (mm)	D <sub>1</sub>	240 ~ 630	
	d	90 ~ 210	
	d <sub>1</sub>	79 ~ 179	
	H	154 ~ 316	
	s	5 ~ 7	
	k	9 ~ 14	
重量 Weight (kg)		27.5 ~ 341	

## 闭式导缆孔 Closed Fairleads

Unit: mm

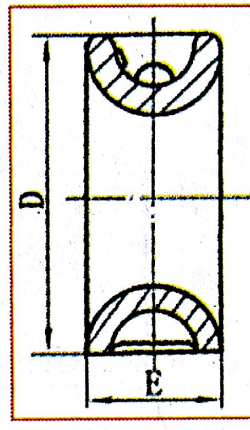
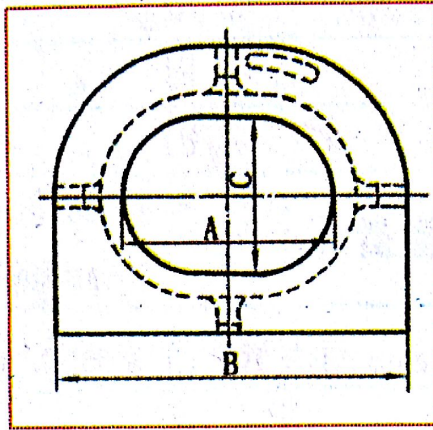
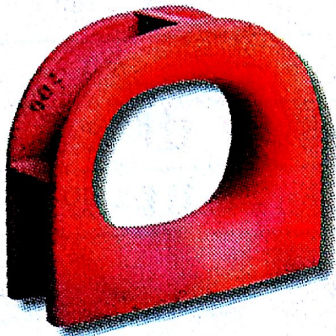

A	100/150/200
B	170/250/340
C	76/110/150
D	141/205/280
E	60/90/120
重量 Weight(kg)	3.7/10.5/24.0

- ↓ Notes: 1. Certificate ABS, BV, CCS, DNV, GL, KR, LR, NK, RINA.  
2. According With JIS F2005-1975

Code: 112106

☼ 供应商: 2112

☼ Supplier: 2112

## 系泊式导缆孔(A型) Mooring Fairleads(A)

Unit: mm

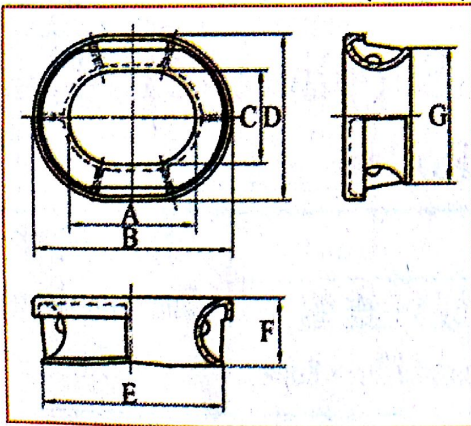

A	150 ~ 500
B	300 ~ 760
C	110 ~ 250
D	260 ~ 510
E	129 ~ 219
重量 Weight(kg)	15.1 ~ 115

- ↓ Notes: 1. Certificate ABS, BV, CCS, DNV, GL, KR, LR, NK, RINA.  
2. According With JIS F2007-1976

## 巴拿马导缆孔(AC型) Panama Fairleads (AC)

Unit:mm

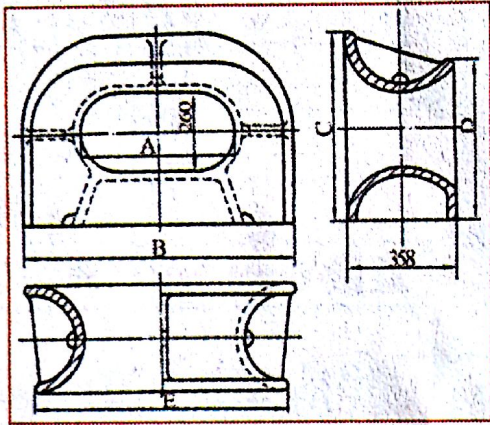

A	310 ~ 500
B	708 ~ 908
C	639 ~ 644
D	541 ~ 549
E	652 ~ 854
重量 Weight (kg)	253 ~ 395

↓ Notes: Certificate ABS, BV, DNV, GL, KR, NK.

Code:112094

☼ 供应商: 2112

☼ Supplier: 2112

## 巴拿马导缆孔(BC型) Panama Fairleads (BC)

Unit: mm

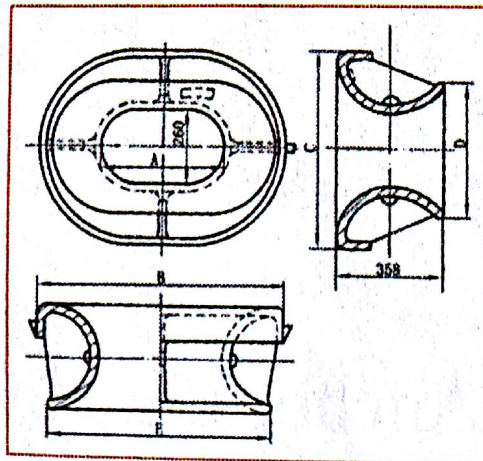

A	310 ~ 500
B	734 ~ 940
C	684 ~ 700
D	462 ~ 478
E	652 ~ 854
重量 Weight(kg)	276 ~ 422

↓ Notes: 1. Certificate ABS, BV, CCS, DNV, GL, KR, , LR, NK, RINA.  
2. According With JIS F 2017-1982.