

Mooring Winch 系泊绞车

Code: 170111

🚩 供应商: 2663

🚩 Supplier: 2663

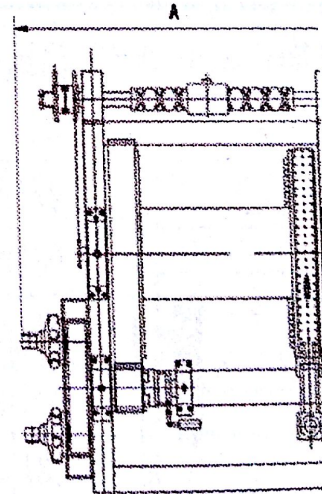
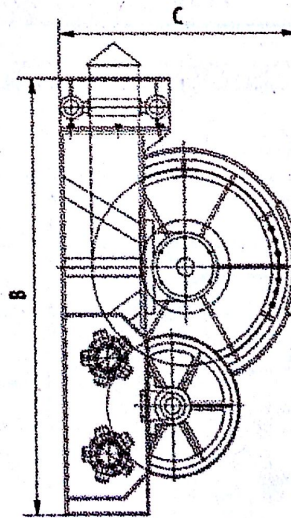
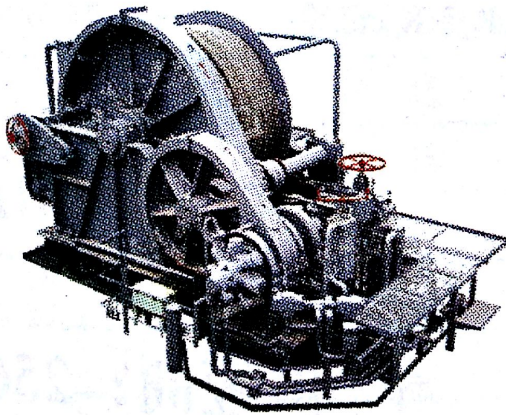

型号 Type	额定 拉力 Rated Pull(kN)	额定 速度 Rated Speed (m/min)	卷筒 容绳量 Drum Capacity (mm × m)	支持 负载 Supporting Load (kN)	电机 功率 Motor Power (kW)	外形尺寸Dimensions (mm)			整机 重量 Weight (t)
						A	B	C	
YBDA-20	200	10	36 × 300	500	75	2500	2680	1680	8.6
YBDA-25	250	10	42 × 500	625	90	2580	2750	1700	13.2
YBDA-28	280	12	42 × 500	700	110	2850	3500	2200	14.3
YBDA-30	300	12	42 × 500	750	110	3500	4000	2500	16.5
YBDA-40	400	10	52 × 600	1000	150	3620	4000	2480	25.2
YBDA-50	500	14	60 × 1500	1250	225	3960	4150	2635	26.8
YBDA-75	750	10	64 × 850	1500	250	2980	4620	3150	32.2
YBDA-85	850	12	64 × 860	1700	330	3800	4800	3000	36.6

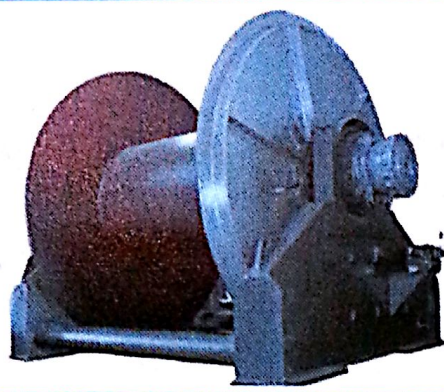

驱动形式 Drive	Electric/Hydraulic
结构 Configuration	Single Drum
钢丝卷筒 Wire Drum	Steel Wire Rope/ Steel Wire Rope Drum
额定拉力 Rated Pull (1ST LAYER)	2 ~ 15 tonnes
速度 Wire Speed (m/min)	Up to 30
控制 Control	Local and/or remote control

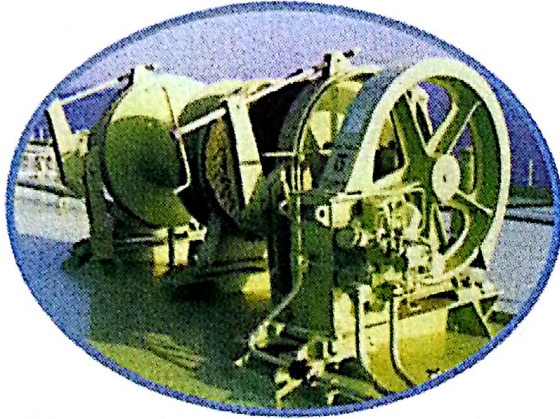

Code: 170116

☼ 供应商: 3580

☼ Supplier: 3580

系泊绞车 Mooring Winch

型号 Type	卷筒 负载 Drum Load (kN)	公称速度 Nominal Speed (m/min)	空载速度 Non-load Speed (m/min)	钢绳 Wire Rope (mm)	尼龙绳 Rope (mm)	最大 负载 Max. Load (kN)	卷筒规格 Drum Dia. × Width (φ mm × mm)	容绳量 Rope Capacity (m)
100HW	100	15	45	25	-	260	457 × 880	300
				-	60		457 × 800	226
				-	-		457 × 1100	301
130HW	125	15	46.9	28	-	350	457 × 880	300
				-	65		457 × 800	226
				-	-		457 × 1100	301
160HW	160	15	46.9	32	-	470	558 × 880	287
				-	70		457 × 800	226
				-	-		457 × 1100	301
200HW	200	15	47.1	38	-	590	609 × 880	267
				-	80		508 × 850	214
				-	-		508 × 1180	306
250HW	250	15	52.5	42	-	730	680 × 880	268
				-	80		508 × 850	214
				-	-		508 × 1180	306
300HW	300	15	52.5	42	-	838	680 × 880	268
				-	80		508 × 850	214
				-	-		508 × 1180	306

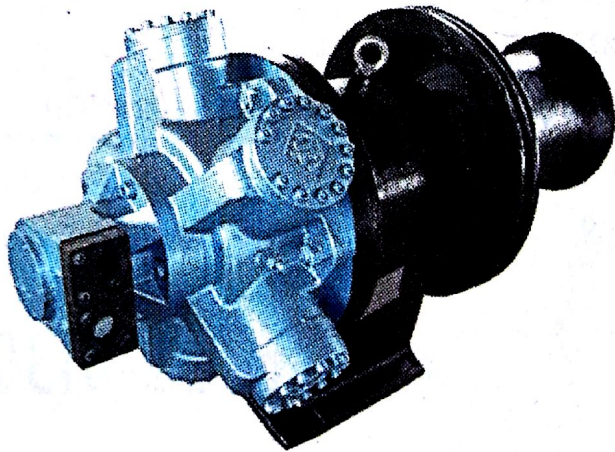

Code: I70123

☼ 供应商: 2680
☼ Supplier: 2680

RQJ6 液压绞纲机 Winch

额定拉力 Rated Pull (kN)	绞拉线速度 Speed (m/min)	系统额定压力 Rated Pressure (Mpa)
60	80	16

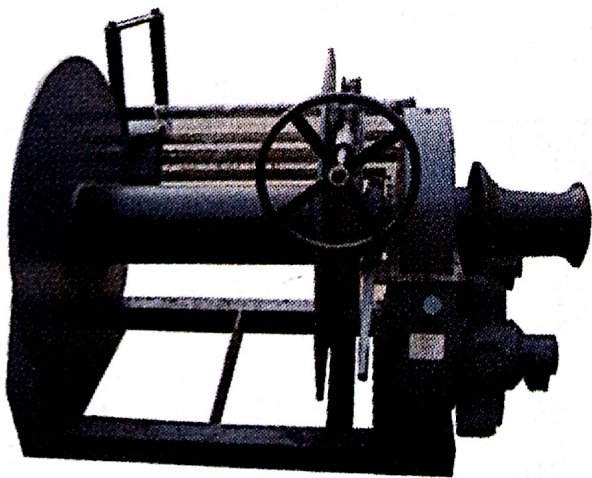

Code: I70124

☼ 供应商: 2680
☼ Supplier: 2680

RQG6 液压卷纲机 Rope Reel

额定拉力 Rated Pull (kN)	绞拉线速度 Speed (m/min)	系统额定压力 Rated Pressure (Mpa)
60	80	16

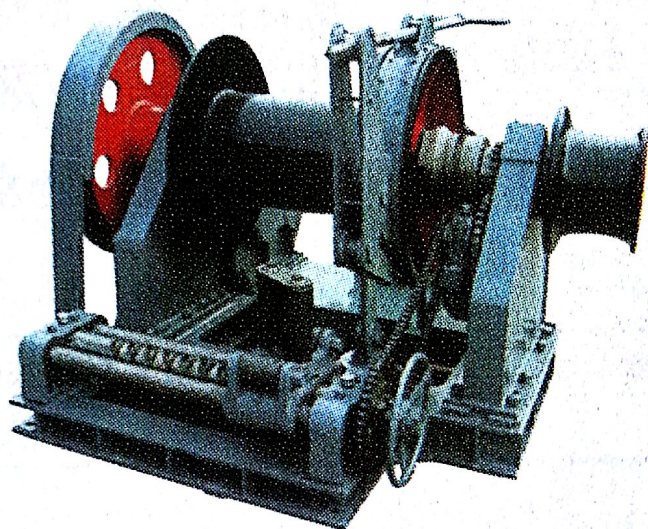

Code: I70130

☼ 供应商: 2362
☼ Supplier: 2362

绞车 Mooring Winch

图号 Chart Code	额定负载 Rated Load (kN)	额定速度 Rated Speed (m/min)	容绳量 Capacity (m)	钢索直径 Wire Rope Dia. Φ (mm)
245Q84-1-00A	10	30/7	280	12.5
245SC563-00	10	16	35	11
244QJ-5-00	6	28	540	24
245Q84.1-00	30	30/7.5	750	12.5
245QJ-6-00	30	13	300	20
245QJ-16-00	30	8.04	180	17
245Q45-31-00	30	6	300	16
244QJ-8-00A	50	>6	500	24
245QJ-10-00	50	34.1/16.2/7.3	90	22.5
245QJ-19-00	50	8	200	24
245QJ45-26-00	25/50	21/10/5	150	20
244BC2-00	50	15	300	32
245QJ-32-00	60	15/7.2/3.6	400	39
245Q83.6 II -00	63	0-38	400	20.5

⚓ Notes: Certificate CCS

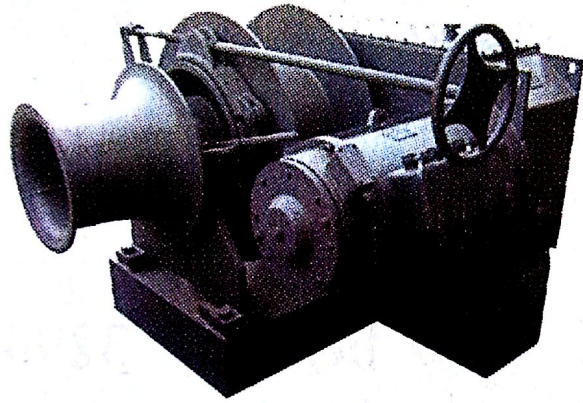

Code:170153

☼ 供应商: 2371

☼ Supplier: 2371

电动单卷筒系泊绞车 Electric Single Drum Mooring Winch

型号 Type	卷筒负载 Drum Load(kN)	公称速度 Nominal Speed(r/min)	支持负载 Supporting Load(kN)	钢索直径 Wire Rope Dia.(mm)	容绳量(m) Drum Capacity
DB-30/0.25	30	15	90	16	150
DB-50/0.25	50	15	150	20	180
DB-75/0.25	75	15	220	26	180
DB-80/0.25	80	15	240	26	200
DB-100/0.25	100	15	300	28	200
DB-150/0.25	150	15	450	32	250
DB-160/0.25	160	15	470	32	250
DB-200/0.16	200	9.6	590	40	250
DB-250/0.16	250	9.6	730	44	250
DB-315/0.13	315	7.8	940	52	250
DB-350/0.13	350	7.8	1050	54	250
DB-400/0.13	400	7.8	1080	56	250

↓ Notes: Certificate ABS, BV, CCS, DNV, GL, KR, LR, NK.

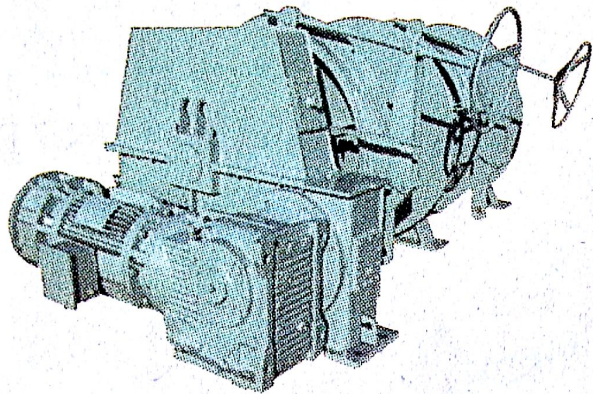

Code: 170156

☼ 供应商: 3294
☼ Supplier: 3294

系泊绞车 Mooring Winch

规格Size		50	75	100	120	160	200	250	315
额定负载Rated Load(kN)		50	73.6	100	122.5	160	200	250	315
额定速度Rated Speed(r/min)		15	15	15	15	15	15	15	15
空载No-load Speed(r/min)		45	45	45	45	45	45	45	45
制动拉力Braking Force(kN)		150	220	260	350	470	590	730	880
滚筒规格 Drum Size Dia. × Length (mm)	Hawser	φ 400 × 900	φ 450 × 900	φ 450 × 1050		φ 450 × 1050	φ 500 × 1100	φ 550 × 1150	
	Wire	φ 400 × 600	φ 500 × 650	φ 600 × 650		φ 650 × 650	φ 650 × 650	φ 710 × 650	
滚筒容绳量 Drum Capacity (mm) × (m)	Hawser	φ 65 × 200	φ 70 × 200	φ 75 × 220		φ 75 × 220	φ 80 × 220	φ 85 × 250	
	Wire	φ 30 × 200	φ 31.5 × 200	φ 34 × 200		φ 40 × 200	φ 40 × 200	φ 44 × 250	
功率 Power(kW)		15	22	30	37	50	60	75	75

↓ Notes: 1. According to JIS F 6709; 2. Certificate ABS, BV, CCS, DNV, GL, KR, LR, NK.

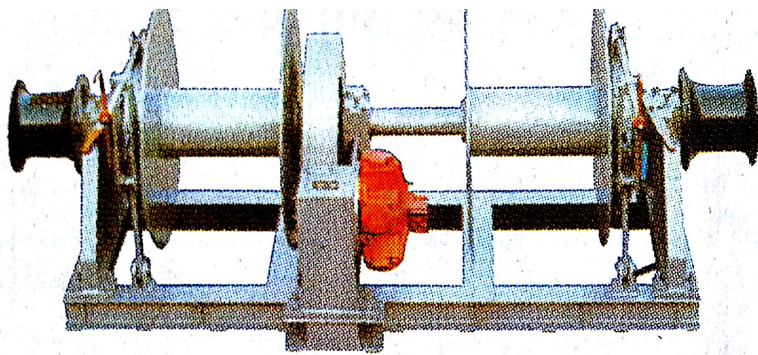

Code: 170181

☸ 供应商: 2163
 ☸ Supplier: 2163

液压系泊绞车 Mooring Winch

型号Type	YB□-30	YB□-50	YB□-80	YB□-125
滚筒负载Drum Load(kN)	30	50	80	125
速度Speed (m/s)	0.25	0.25	0.25	0.25
绳索直径Rope Dia.(mm)	65	75	85	30(tightwire)
支持负载Supporting Load(kN)	90	150	240	310
容绳量 Drum Capacity(m)	150	150	180	200

⚓ Notes: Certificate CCS.